



MRS-350/350CC

MRS Reverse Osmosis System

Configurable system that delivers reverse osmosis or blended water for multiple foodservice applications



MRS-350 System: EV9970-17
 MRS-350CC System: EV9970-18
 Pre-Filter Kit: EV9795-81
 7TO-BW Cartridge: EV9607-04
 MR-350 Cartridge: EV9627-07
 7CC-BW Cartridge: EV9627-05
 P5 Cartridge: EV9109-08

* System shown with optional Pre-filter kit.

BENEFITS

Improves equipment life and performance by removing at least 90%+ of all dissolved solids that cause scale build-up

Guards against taste and odor causing contaminants while removing dirt, particulates and dissolved minerals that can adversely affect taste of water and beverages

Sanitary cartridge replacement is simple, quick and clean. Internal filter parts are never exposed to handling or contamination

Wall mount design allows flexible installation

Reduces limescale build-up that can cause excessive machine downtime and increased maintenance costs. Plus, scale reduction reduces energy costs

"CC" models introduce a small amount of hardness minerals back into the treated water. This controlled re-mineralization is desirable for coffee and other applications that require some hardness to achieve optimum results

INSTALLATION TIPS

Choose a mounting location suitable to support the full weight of the system when operating

Delimiting of equipment prior to application is recommended

Never use saddle valve for connection

Use 3/8" (min.) water line

The water inlet must supply a minimum of 1.0 gpm

Install vertically with cartridge hanging down and allow 2 inches above and below unit for cover removal and service access

Allow clearance to right of unit for optional pre-filter

Refer to Installation, Operation & Maintenance Manual for cartridge flushing and RO start-up

OPERATION TIPS

Change filter cartridges on a regular 6-month preventative maintenance program

Change RO cartridges on a regular 2-year preventative maintenance program

Change cartridges when capacity is reached

Proper pre-treatment is required to control RO Cartridge (membrane) scale formation and/or fouling

- Raw water hardness in excess of 7 grains per gallon should be softened
- The raw water may contain particulates and the use of a pre-filter is recommended

Contact EVERPURE Technical Service for pre-treatment recommendations

APPLICATION/SIZING

Mineral Reduction System for foodservice applications

Ideal for: Flash steamers, conventional steamers, cheese melters, combi-ovens and coffee/espresso machines

Output capacity: 350 gallons per day (1,325 lpd)

For use in coffee, steam, reconstitution, ice and multiple applications

MRS Reverse Osmosis System

SPECIFICATIONS

Overall Dimensions:

38"H x 15"W (20.5" with Prefilter) x 8"D

Inlet and outlet connection:

3/8" OD tube connection

Wastewater line connection:

1/4" OD tube connection

Service Flow Rate:

Dependant on water pressure in storage tank and line size(s) to equipment

Pressure Requirements:

Operating:

25 - 80 psi (172-552 kPa), non-shock

Maximum Static:

100 psi (689 kPa), non-shock

Electrical connection required:

115 Volts AC, 60 Hertz, 1 Phase

Water Supply:

1 gpm (3.8l) min.

Inlet Temperature:

40°F - 100°F (4-38°C)

Inlet TDS:

1,500 ppm max recommended

Operating Weight: 35 lbs.

(not including storage tanks)

The contaminants or other substances removed or reduced by this system are not necessarily in your water. Do not use with water that is microbiologically unsafe or of unknown quality without adequate disinfection before or after the system.

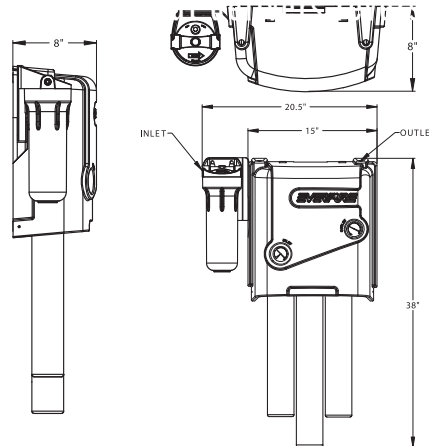

WARRANTY

MRS-350/350CC system (excluding replaceable elements) is covered by a limited warranty against defects in material and workmanship for a period of one year after the date of purchase.

Everpure replaceable elements (filter cartridges and water treatment cartridges) are covered by a limited warranty against defects in material and workmanship for a period of one year after date of purchase. See printed warranty for details. Everpure will provide a copy of the warranty upon request.

EVERPURE®

Worldwide Headquarters:
EVERPURE, LLC
1040 Muirfield Drive
Hanover Park, Illinois 60133
Toll Free (800) 323-7873
Tel (630) 307-3000
Fax (630) 307-3030
<http://www.everpure.com>

In Europe:
Pentair Water Belgium B.V./B.A.
Industriepark Wolfstee
Toekomstlaan 30
B- 2200 Herentals
BELGIUM
TEL: +32.(0).14.283.500
FAX: +32.(0).14.283.505

In Japan:
Hashimoto MN Bldg. 7F
3-25-1 Hashimoto Sagamihara-Shi
Kanagawa 229-1103
JAPAN
TEL: 81.(0)42.775.3011
FAX: 81.(0)42.775.3015

Everpure
1040 Muirfield Drive
Hanover Park, IL 60133